

典型性能 Features

- ◆ 20 瓦功率输出 (20 Watts of Output Power)
- ◆ 超宽电压输入 (4:1 Wide Range Input)
- ◆ 长期短路保护, 自恢复 (Short Circuit Protection, Automatic Recovery)
- ◆ 小型化封装 (Small Package)



电气特性 Electrical Specifications

输入特性 Input	Min	Type	Max	Notes
输入电压范围	9V	12V/24V	36V	
Input Voltage Range	18V	24V/48V	72V	
	40V	74V/110V	160V	
启动延时时间 Start-up Delay Time		10mS		
控制功能		ON		CNT 悬空或接TTL高电平 CNT pin left open or CNT pin connected to TTL logic high
ON/OFF Control		OFF		CNT 与-Vin 相连 CNT pin is at a logic low
逻辑低 Logic Low			1.2 V	
输入欠压保护	6V		9V	9-36V 输入
Input. Under-voltage Lockout	13V		18V	18-72V 输入
	30V		40V	40-160V 输入
输出特性 Output	Min	Type	Max	Notes
输出电压精度		±1%	±3%	一路
Set point Accuracy		±3%	±5%	二路
负载效应		±0.5%	±1%	二路
Load Regulation				
源效应		±0.2%	±1%	二路
Line Regulation				
输出电压调节			±10%	
TRIM Range				
动态响应			4%Vo Pk deviation 400μS settling time	50~75% load 50~25% load
Dynamic Response				
温度系数		±0.2%/°C		
Temperature Regulation				
输出过流保护	110%		160%	
Current Limit Threshold				
输出过压保护	110%		140%	
Over-voltage Protection				
短路保护	长期短路自恢复			
Short-Circuit Protection	Continuous, Automatic Recovery			
综合特性 General	Min	Type	Max	Notes

隔离电压 Isolation Voltage	1500Vdc			INPUT TO OUT
开关频率 Switching Frequency		300KHz		
平均故障间隔时间 MTBF		2×10 ⁶ Hrs		Mil HDBK 217F Tc=25°C
工作壳温 Case Temperature	工业级	-40°C		+100°C
	AD、AG 级	-40°C		+105°C
	AHII 级	-55°C		+105°C
储存温度 Storage Temperature		-55°C		+125°C
相对湿度 Relative Humidity		10%		90%
管脚焊接温度 Pin Solder Temperature				250°C Wave Solder <10S
手工焊接时间 Hand Soldering Time				5S Iron Temperature 425 °C
传导 Conducted Emission	GB9254/CISPR22/EN55022 Class B (推荐电路见图)			
静电放电 Electrostatic Discharge	GB17626/EN61000-4-2 Contact ±6KV air ±8KV (推荐电路见图) perf. CriteriaA			
浪涌抗扰度 Surge Immunity	GB17626/EN61000-4-5 ±2KV (推荐电路见图) perf. Criteria A			
脉冲群抗扰度 Electrical Fast Transient	GB17626/EN61000-4-4 ±2KV (推荐电路见图) perf. Criteria A			

型号 Models	输入电压范围 Input Voltage Range	输出电压 (Vdc) Output Voltage	输出电流 (A) Output current	纹波噪声(mv) Ripple and noise	典型效率 Efficiency	容性负载 (μF) Max.Capacitor Load
WD20-24S3V3WS	9-36V	3.3	5.0	50	86%	6800
WD20-24S5WS	9-36V	5.05	4.0	80	90%	6800
WD20-24S9WS	9-36V	9	2.22	100	87%	1000
WD20-24S12WS	9-36V	12	1.67	120	88%	680
WD20-24S15WS	9-36V	15	1.33	150	89%	680
WD20-24S18WS	9-36V	18	1.11	150	89%	470
WD20-24S24WS	9-36V	24	0.83	240	90%	470
WD20-24S28WS	9-36V	28	0.71	280	90%	470
WD20-24S48WS	9-36V	48	0.42	480	87%	100
WD20-48S3V3WS	18-72V	3.3	5.0	50	86%	6800

WD20-48S5WS	18-72V	5.05	4.0	80	90%	6800
WD20-48S9WS	18-72V	9	2.22	100	89%	1000
WD20-48S12WS	18-72V	12	1.67	120	89%	680
WD20-48S15WS	18-72V	15	1.33	150	89%	680
WD20-48S24WS	18-72V	24	0.83	150	90%	470
WD20-48S24WS	18-72V	24	0.83	240	90%	470
WD20-48S48WS	18-72V	48	0.42	280	87%	100
WD20-110S3V3WS	66-160V	3.3	5.0	50	86%	6800
WD20-110S5WS	66-160V	5.05	4.0	80	89%	6800
WD20-110S9WS	66-160V	9	2.22	100	89%	1000
WD20-110S12WS	66-160V	12	1.67	120	88%	680
WD20-110S15WS	66-160V	15	1.33	150	88%	680
WD20-110S24WS	66-160V	24	0.83	240	90%	470
WD20-110S48WS	66-160V	48	0.42	480	86%	100
WD20-24D5WS	9-36V	±5.05	±2.0	100	85%	2200
WD20-24D12WS	9-36V	±12	±0.83	120	87%	220
WD20-24D15WS	9-36V	±15	±0.67	150	87%	220
WD20-48D5WS	18-72V	±5.05	±2.0	100	85%	2200
WD20-48D12WS	18-72V	±12	±0.83	120	88%	220
WD20-48D15WS	18-72V	±15	±0.67	150	88%	220
WD20-110D5WS	66-160V	±5.05	±2.0	100	85%	2200
WD20-110D12WS	66-160V	±12	±0.83	120	87%	220
WD20-110D15WS	66-160V	±15	±0.67	150	87%	220

■说明：仅列出典型型号，其它型号，请确定功率，输入电压及输出电压，致电我公司。

磁兼容应用 (EMC)

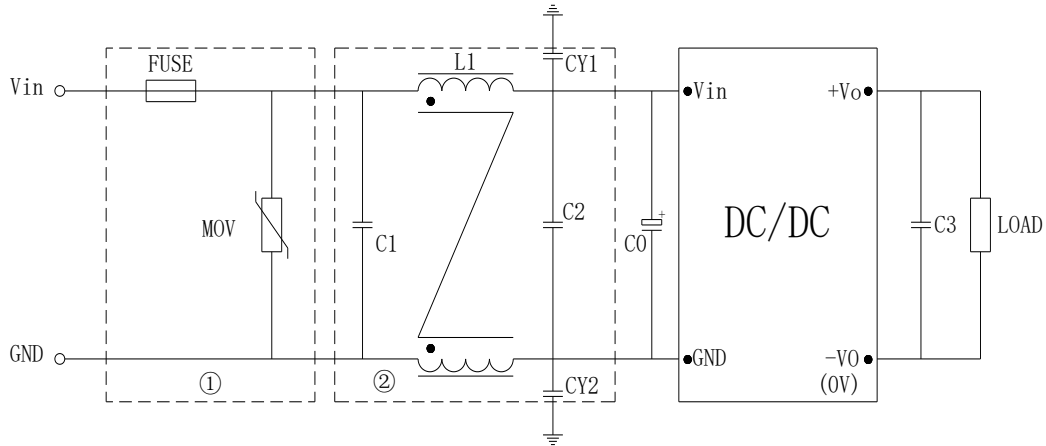

FUSE:推荐采用慢熔型的产品, FUSE 电流选择要考虑高温降额和冲击电流的影响。

MOV:压敏电阻, MOV 可以和保险丝串联应用, 防止 MOV 失效。也可以两只 MOV 串联, 增加可靠性。

C0 C3:高频电解电容

C1 C2:高频独石电容或者薄膜电容。

LCM:共模电感。具体型号请咨询销售人员。

CY1 CY2:安规 Y2 电容

型号	Vin: 24V	Vin: 48V	Vin: 110V
FUSE	4A 慢熔	2A 慢熔	2A 慢熔
MOV	14D101K	14D101K	14D201K
C0	220 μ F/50V	100 μ F/100V	68 μ F/250V
C1、C2	4.7 μ F/50V	2.2 μ F/100V	1 μ F/250V
C3	100 μ F		
LCM	3mH		
CY1、CY2	4.7nF Y2 安规电容		

输出调节应用 (TRIM Function)

电源 TRIM 脚可以实现输出电压调节功能

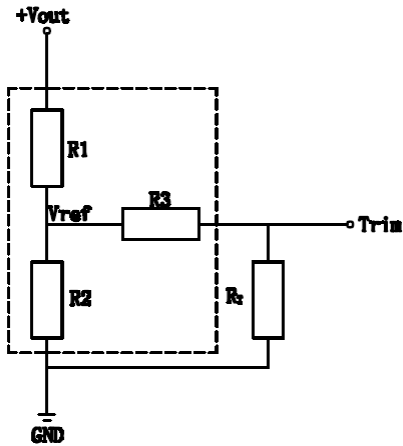

$$up : R_T = \frac{TR_2}{R_2 - T} - R_3 \quad T = \frac{V_{ref}}{V_o' - V_{ref}} \cdot R_1$$

$$down : R_T = \frac{TR_1}{R_1 - T} - R_3 \quad T = \frac{V_o' - V_{ref}}{V_{ref}} \cdot R_2$$

Trim up

Vout (V)	R1(KΩ)	R2(KΩ)	R3(KΩ)	Vref(V)
3.3	3.32	2.0	8.2	1.24
5	2.55	2.49	8.2	2.5
9	6.51	2.49	12	2.5
12	9.53	2.49	12	2.5
15	12.5	2.49	15	2.5
24	21.5	2.49	20	2.5
28	25.5	2.49	20	2.5
48	45.32	2.49	20	2.5

遥控应用 (CNT Function)

CNT 管脚可以实现电源的开关功能，既可通过开关实现，也可通过与 CNT 端子串联的晶体管实现。在有些应用中可能要用到隔离控制，可通过光耦或继电器进行。当控制线很长时可能在 CNT 端引入一些干扰，建议在 CNT 端和 -Vin 之间并接一个 0.1uF 电容。

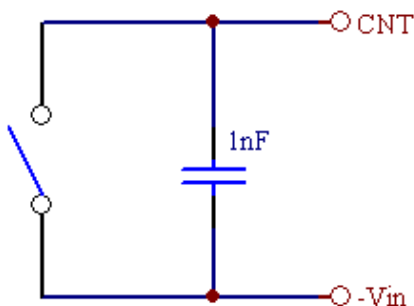

机械图及管脚说明 (Mechanical Chart、Pins) (Unit: mm/inch)

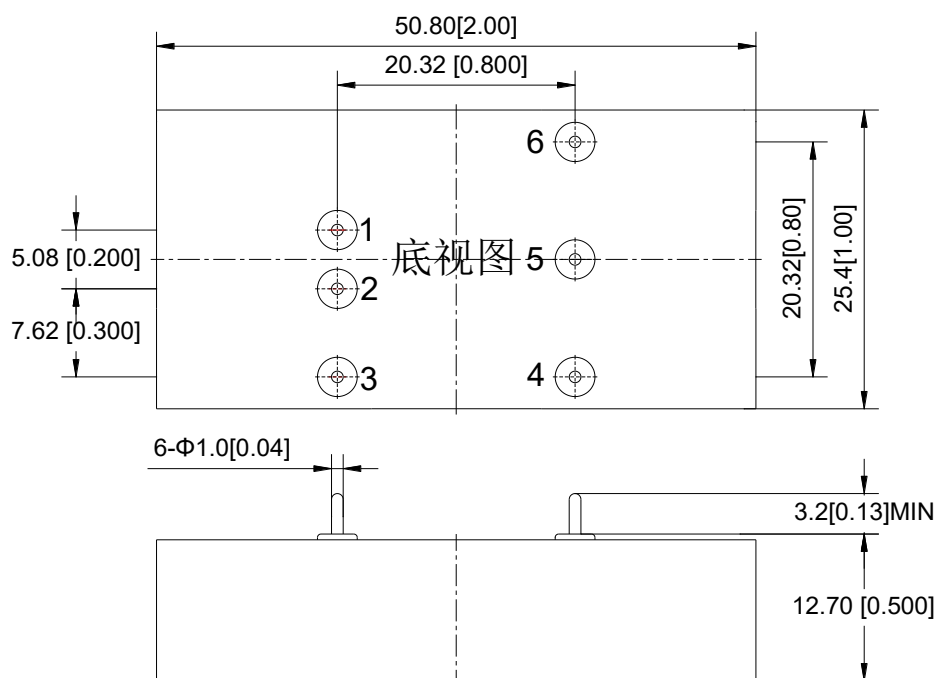

管脚	1	2	3	4	5	6
单路	+Vin	-Vin	CNT	-Vo	TRIM	+Vo
双路	+Vin	-Vin	CNT	-Vo2	COM	+Vo1

注:安装定位尺寸公差按 GB/T1804-2000 F 级标准、外型尺寸公差按 GB/T1804-2000 C 级标准。

尾缀为 D1 的机械图

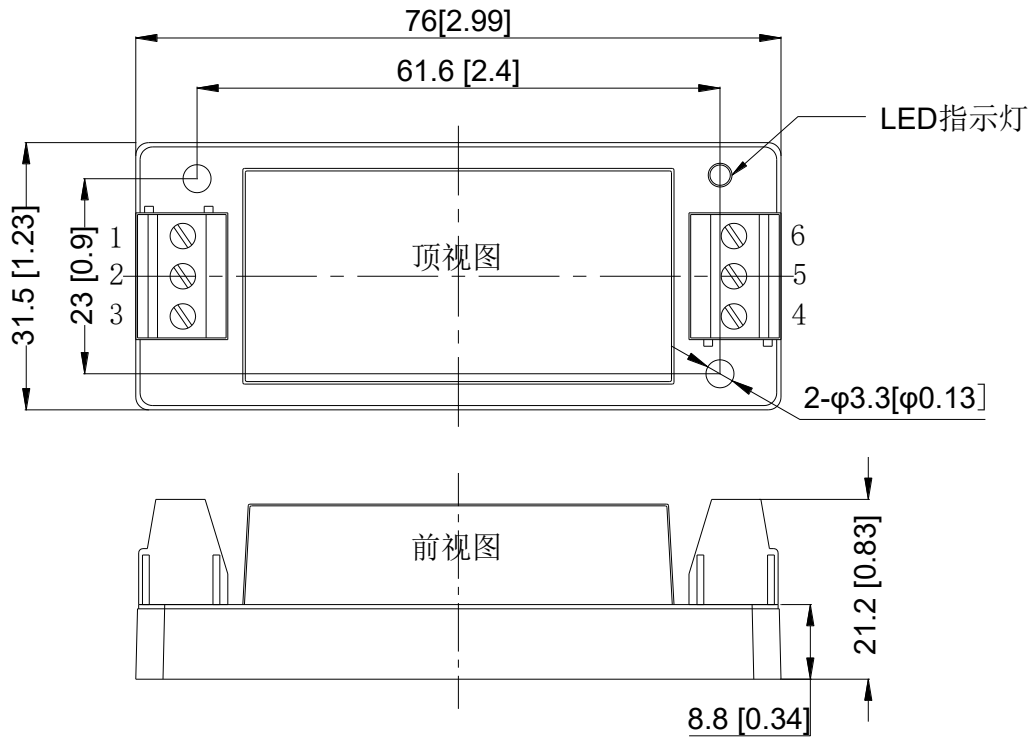

接线线径: 24-12AWG

紧固力矩: Max 0.4N.m

管脚 Pin	1	2	3	4	5	6
单路	CNT	-Vin	+Vin	+Vo	TRIM	-Vo
双路	CNT	-Vin	+Vin	+Vo	COM	-Vo

尾缀为 D2 的机械图

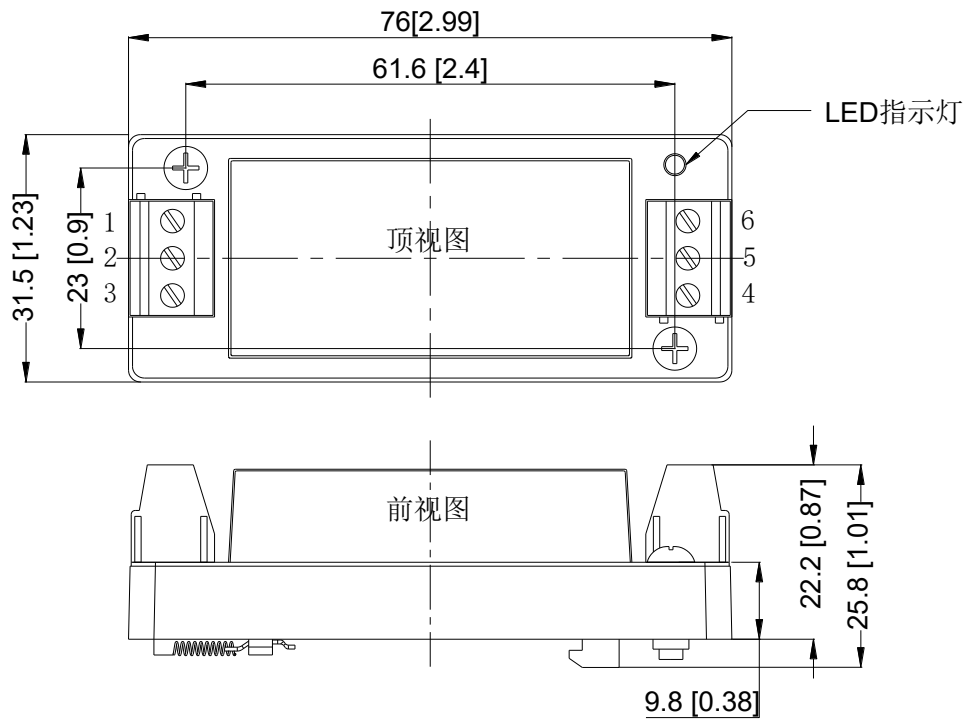

接线线径: 24-12AWG

紧固力矩: Max 0.4N.m

管脚 Pin	1	2	3	4	5	6
单路	CNT	-Vin	+Vin	+Vo	TRIM	-Vo
双路	CNT	-Vin	+Vin	+Vo	COM	-Vo

注:安装定位尺寸公差按 GB/T1804-2000 F 级标准、外型尺寸公差按 GB/T1804-2000 C 级标准。